

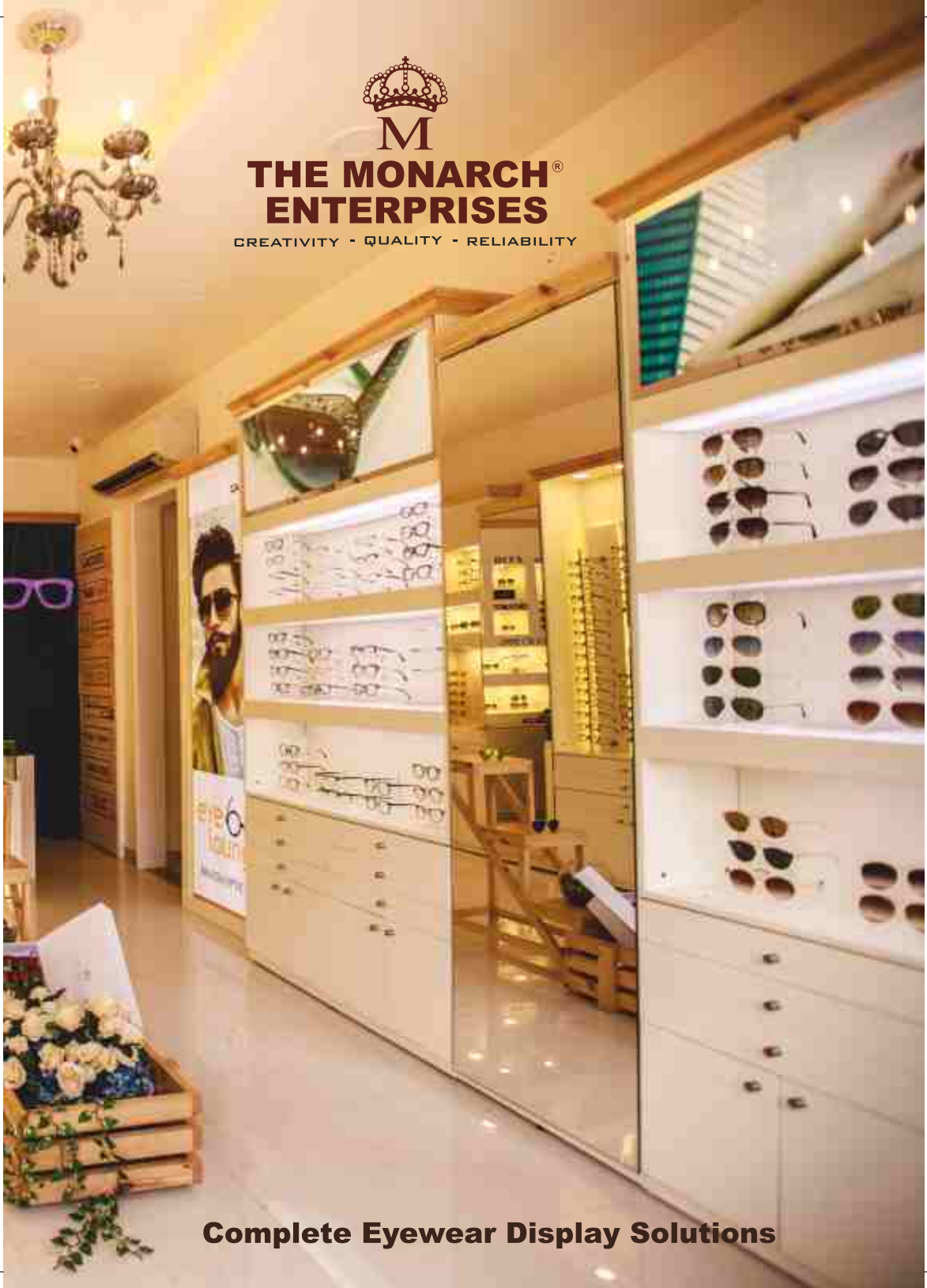

# THE MONARCH<sup>®</sup> ENTERPRISES

CREATIVITY - QUALITY - RELIABILITY



**Complete Eyewear Display Solutions**

## **CORE VALUES**

Customer Satisfaction  
Ethical Work Standards  
Commitment To Commitments  
Elevation Of Industry Standards  
Employee Development  
Integrity

---

## **CORE PURPOSE**

To Provide Unique Solutions  
To People And Organizations  
Through Constant Innovation

---

## **STRENGTHS**

Quality Products  
Latest Trends  
Timely Deliveries  
Technical Expertise  
After Sales Service

---

## **SERVICES**

Showroom Display Solutions  
Showroom Design  
Lockable & Non-Lokable Rods  
Revolving & Non-Revolving Stands  
P.O.P. Display Solutions for Brands  
Acrylic Fabrication  
Optical Accessories  
Modular Furnitures

---





## THE COMPANY

### *Who we are*

Established in 1998, **THE MONARCH ENTERPRISES** is one of the leading manufacturers of Optical Display Solutions in India. Our designs are functional & personalized. Modular furniture is fast becoming the perfect answer to a quickly created, beautiful optical environment. Our team is able to create customized and knock-down components that add for a cost-effective and easily re-configurable solution.

### *How Monarch Enterprises can help your brand*

With all the competition out there your brand needs to stand out. Your designers may give you a beautiful new innovative design for a display or interiors, but what next? If you hand that over to just any manufacture, it is impossible to know what would be the output. That's where we step in.

The Monarch Enterprises is one of the leading providers in the optical industry in design and manufacturing of custom made optical displays: Lockable and Non-Lockable Rods, Lens Trays, Frame Trays, Acrylic Displays, Revolving Stan, Mirrors, Portable Eye Camps Stands, Travel Bags, Portable Trolleys, Modular Furniture and Showroom planning & designing that enhances your brand value and optimizes your customers experience.

For more than a decade, over hundreds of clients have trusted us with their showroom needs, and our high quality products and unparalleled service have ensured that they return for their future and showroom expansion needs.

We believe that every customer should be presented with an experience that sparks curiosity and engagement on entering the showroom. Our experience has led us to be involved not only in the set-up but also in the experience created by the interior design, from the moment a customer steps in for that special product to leaving the showroom.

Beautiful as well as functional eyewear display units are important. This keeps the team working relentlessly in providing robust solutions in modular units that are excellent, non-obtrusive and long lasting. Keeping with the trends in the industry and backed by numerous years of experience, we are able to plan and execute all the vital aspects of any optical showroom design. We are not just manufactures or fabricators, we extend our services to cover the management of spaces for aspects of functionality, personalization and beauty by layout and presentation.



DIRECTOR - MURTAZA T

**THE MONARCH ENTERPRISES** is always up to date with the latest trends and technology in shop layout and designing. It is very critical to have a useful eyewear display that optimizes on space constraints and manages to present products in a not so obvious manner.

Important elements like lighting also play a major role in the sale of eyewear, creating the impulse for customers to feel the right emotions to buy the product. Every product is considered for its cost effectiveness, keeping this in mind, we create display units and showcases that are knockdown, can be rearranged, reconfigured, portable and are resalable.

## **SERVICE THAT SETS US APART**

Being a clients-centric organization, we have earned our long-standing reputation by placing you, our customer at the forefront. We recognize that our growth and success. Over the years, we have retained the ideals and integrity that are sometimes overlooked in a competitive business climate.

We stand by our claims and deliver what is promised. It is this outstanding dedication, craftsmanship and service that has earned us a trustworthy name in the industry.

## **OUR PEOPLE MAKE THE DIFFERENCE**

Our team of professionals will always be ready to assist you with their in-depth knowledge and proficiency. Each member of the team has sound production and managerial expertise. This has been the core of our strengths due to which we have managed to surpass clients' expectations.

We take business seriously and deliver on time. Our workflow is managed with complete focus on timelines set by our clients. Fulfilling their needs is the team's foremost objective, one which is backed by several testimonials received from over the years.





## OPTICAL RETAIL SHOWROOMS SHOP IN SHOP MODULAR FURNITURE

Monarch brings you the most innovative optical frame and sunglass display systems in the market today. From single optical merchandising elements for counter or wall display to turnkey design for retail stores, we always provides the most efficient, well-crafted and beautiful frame display selections in the industry. Our expertise utilized the newest materials and trends in acrylic panels, wood styling and metal finishes.

We help you on Expansions, Relocation or Reconstructing for your Space Management. Innovations for your Shop-in-Shop's Visual Merchandising, and Display Solutions by assuring that the job will be done well within the stipulated time line and cost factor for your pre-determined Budget.

### FEATURES

Pre-laminated Machine Pressed MDF Board

Water Proof Ply / Marine Ply With Lamination

MDF Membrane Finish

Various Finishes

Lightweight And Easily Movable

Duco / Pre / Post Forming Finish

Commercial Ply With Lamination

PVC / ABS Edge Banding

Complete Knock Down Pieces



JoJo Optical-Amritsar



Spectacle Hut-Ahmedabad



J L Vakil-Chennai

## **PASSING ON THE BENEFITS TO YOU**

Solution that match your taste and personality

Simple, non-obtrusive installation process

Pre-configured cabinets to save on time and cost

Vast collection of colours, finishes and materials to blend with your interiors seamlessly

All components can be upgraded and re-configured as per requirement

Replacement parts are always in easy availability

## **THE PROCESS**

### **DESIGN**

We provide a comprehensive level of retail optical store environment design, ranging from optical space planning solution to implementation of full service optical showroom, eye hospitals and clinics.

### **VISUALIZATION**

We plan a simulation of the final layout by creating a blueprint of the store. We keep in mind all the components that will make up the complete project, so that a picture of the final design is drawn out for clarity.

### **IMPLEMENTATION**

The most critical stage of the design process, here the team gets to execute the work laid out in the plan and get the final output ready as per the project time line.

# IDEAL MODULAR SHOWROOM





# INDEX

Back Wall Display.....	01
Back Wall Display.....	06
Display Trays.....	10
Counter Trays.....	15
Mirrors.....	16
Eye Wear Display Floor Units.....	19
Poster Design.....	24
Acrylic Display.....	25
Miscellaneous Display.....	31
Folding Portable Stand For Eye Camps .....	34
Modular Furniture .....	35
Modules .....	37
Ideal Modular Showroom .....	38







## BACK WALL DISPLAYS

Lockable Rods

Non-Lockable Rods

Horizontal Rods

We offer an extensive range of Lockable / Non-Lockable Optical Display Systems. Fabricated using high quality materials like poly-propylene plastic, extruded anodized / powder-coated aluminum / steel / M.S. / acrylic / fibre providing both style and stability and are in compliance with the prevailing trends of the industry. Our display products are available in different sizes and specifications and in customized forms to meet various needs.

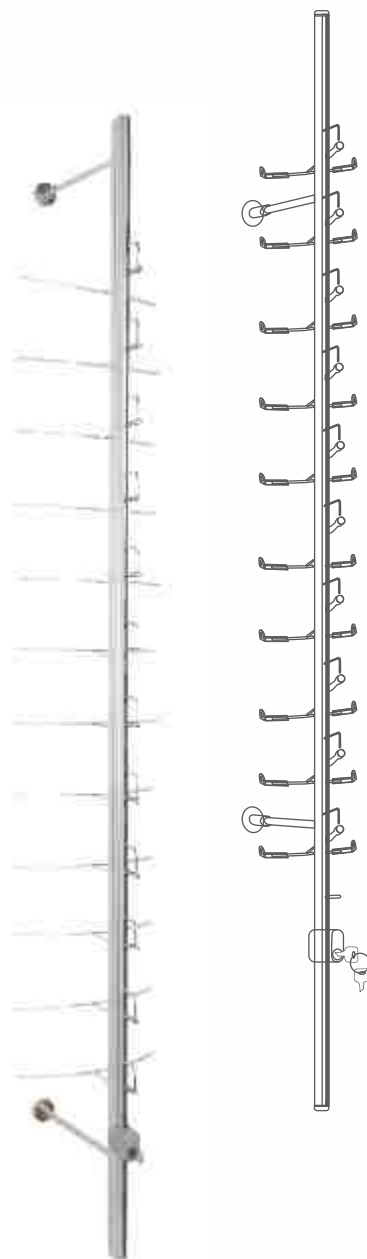

# BACK WALL DISPLAYS

Lockable Rods



## Monarch Acrylic Optical Rods

These Are Clear And  
Transparent Optical /  
Spectacles Display Rods,  
Wall Mounted,  
48 Inches /  
14 Frames Display.

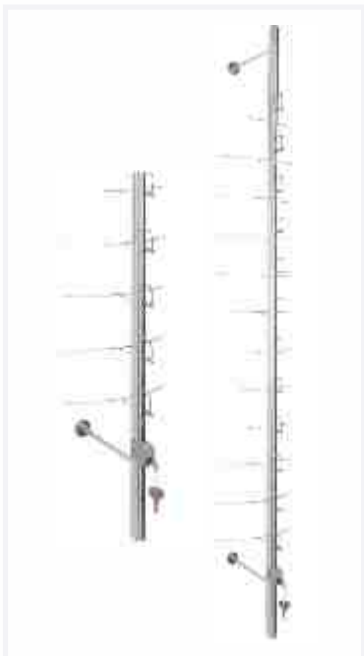

### CONCETTO CPT

Aluminum Rod, Stainless Steel **ME IN L004**  
Accessories with Plastic Tubing Ht: 46 inches = 12 fr  
on Wings Ht: 54 inches = 15 fr  
**Locking System: Hydraulic** Ht: 63 inches = 18 fr

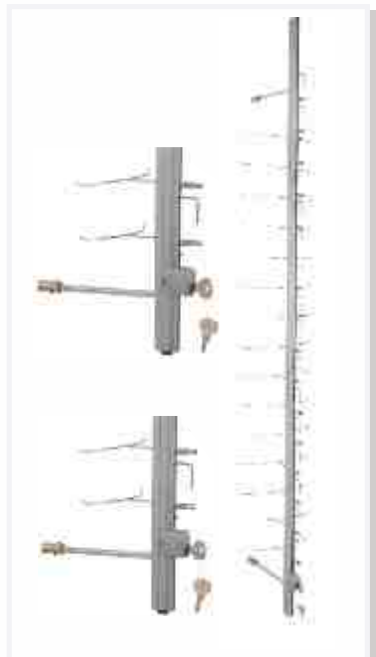

### CONCETTO CPT

Aluminum Rod with  
Mild Steel Accessories **ME IN L007**  
**Locking System: Hydraulic** Ht: 48 inches = 16 fr

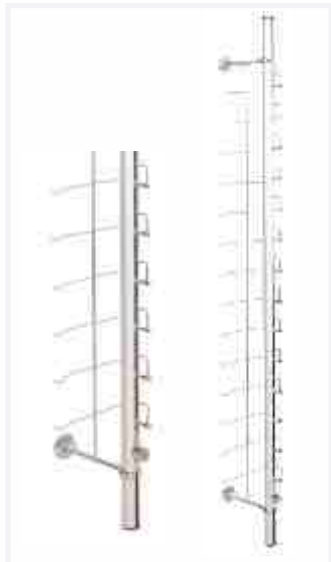

### CONCETTO CPT

Aluminum Thick Rod **ME IP L009**  
with Mild Steel Accessories Ht: 48 inches = 14 fr  
**Locking System: Spring** Ht: 53 inches = 16 fr



### CONCETTO CPT

Aluminum Rod with  
Plastic Accessories **ME IN L010**  
**Locking System: Hydraulic** Ht: 48 inches = 16 fr





# BACK WALL DISPLAYS

## Non-Lockable Rods

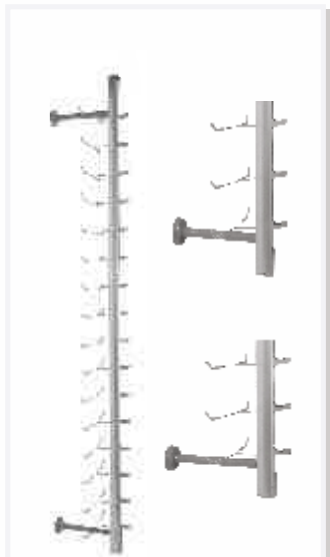

### VISIO

Aluminum Rod,  
Stainless Steel Accessories  
with Rubber Tubing on Wings  
and also in front

### ME IN NL001

Ht: 48 inches = 16 fr

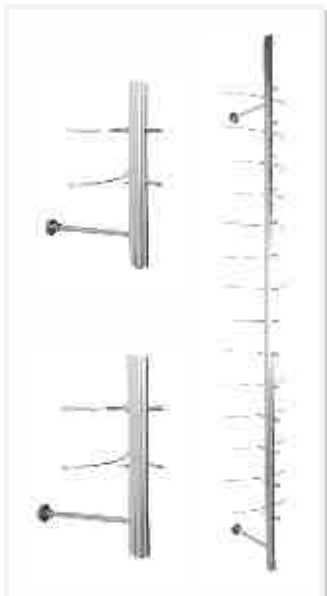

### CONCETTO CPT

Aluminum Rod,  
Stainless Steel Accessories  
with Plastic Tubing on Wings  
and also in front

### ME IN NL002

Ht: 48 inches = 14 fr

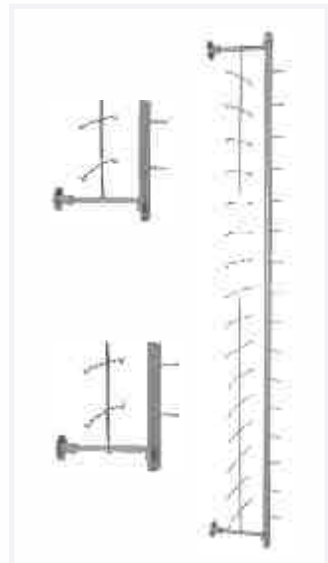

### JUGO

M. S. Rod Powder Coated

### ME IN NL003

Ht: 48 inches = 16 fr

# BACK WALL DISPLAYS

## Horizontal Rods

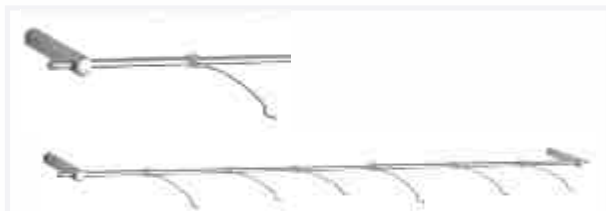

### ORIZON - HR 012

### ME IN NL008 - Lt: 39 inches - 6 Fr



### ORIZON - HR 011

### ME IN NL006 - Lt: 39 inches - 6 Fr

# BACK WALL DISPLAYS

## Non-Lockable Rods

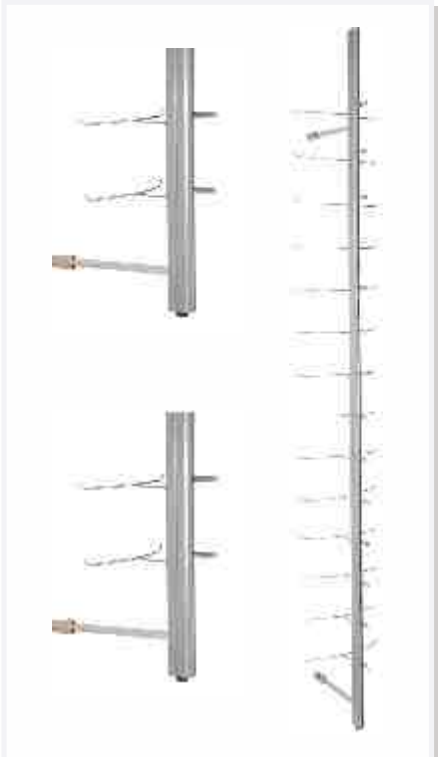

### CONCETTO CPT

Aluminum Rod,  
Mild Steel Accessories  
Plastic tubing in front

### ME IN NL004

Ht: 48 inches = 14 fr

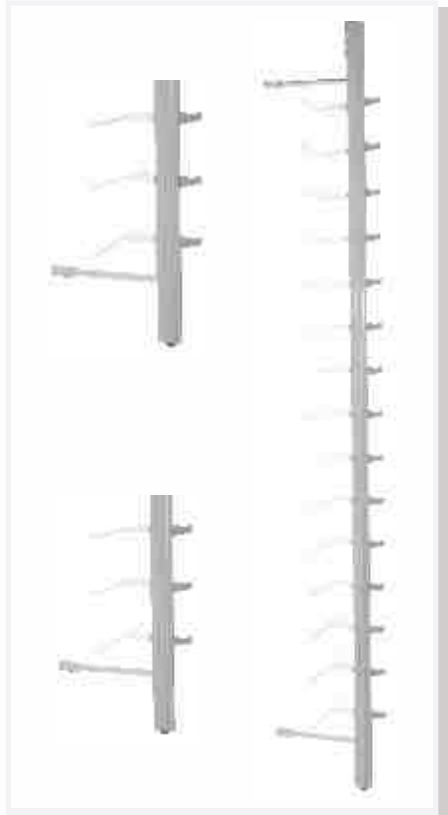

### CONCETTO CPT

Aluminum Rod with  
Plastic Accessories

### ME IN NL005

Ht: 48 inches = 15 fr



BL 001



BL 002



BL 003





WD 001

WD 002



WD 001

Y Spectacle Display

**WD 001**

Y spectacle display made of acrylic glass, dual satin, including adapter

**WD 001 + WD 002**

2 telescope Rods +6 Y spectacle display

**WD 002**

Shelf, round, made of acrylic glass, dual satin, including adapter

**WD 001 + WD 002**

Telescope rod + 8 shelves, round



WD 002

Shelf, Round

## **BACK WALL DISPLAYS**

Non-lockable Displays

Multi Frame Displays

Singular Frame Displays

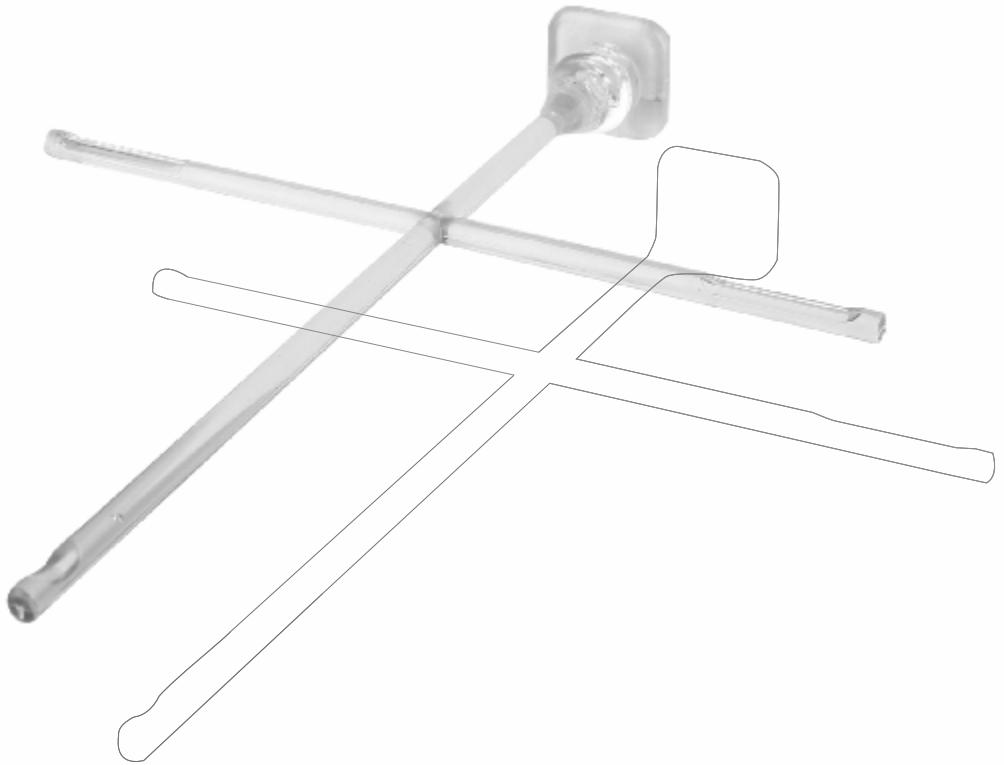

Our extensive range of innovative Backwall display systems singular as well as multi product displays is fabricated using high quality materials like acrylic / fibre having both style and stability and is also in compliance with the prevailing industry trends. Our Display products are available different sizes and specifications and in customised forms to meet various needs.





PM 008



PM 011



OSD 015



PM 006



FOLDING ACRYLIC PANEL

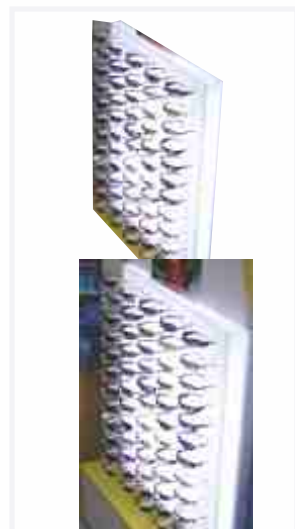

ACRYLIC BACK LIT PANEL  
WITH FINGERS



ENG 001



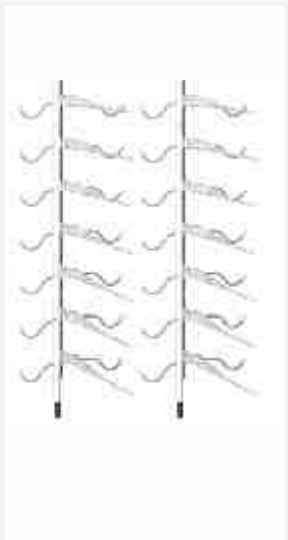

CENTRIC



EYE PANEL  
SD 018 (B)

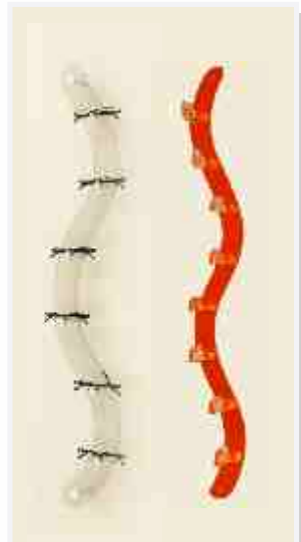

SD 014



OSD 023 SD 002A  
SD 002B SD 001



LED PANEL  
WITH LIGHTS



LED PANEL  
WITH LIGHTS





PM 007  
FOR BIG SUNGLASS



PM 005



PM 001



PM 004



PM 002



PM 003  
FOR FRAME & SUNGLASS



OSD 025



FOLDING ACRYLIC PANEL



TR 051 (A)



OI 013



LT 003



LT 007



CT 008 (A)

## DISPLAY TRAYS

STOCK TRAYS

PRESENTATION TRAYS

COUNTER TRAYS

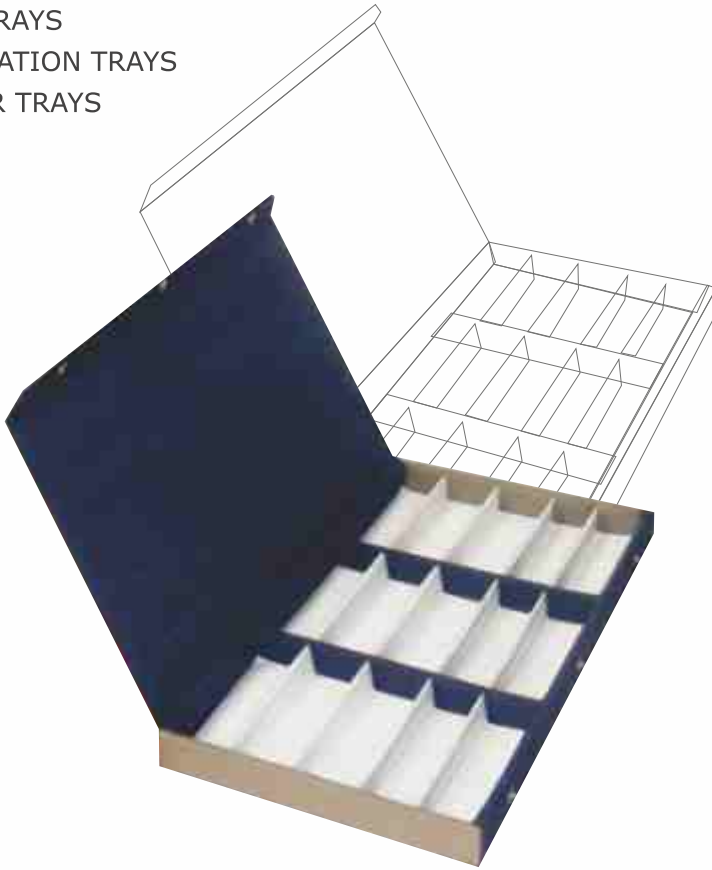

Known to be one of the biggest manufacturers of Eyewear Display Trays, we offer an extensive range of innovative and highly functional trays. Our materials are of a high quality. Our finish is you the optimum usability. Our Display Trays are available in different sizes and specifications and in customized forms to meet various needs.





TR 005



TR 037



TR 023



TR 013



TR 053



TR 039



TR 037

24 FR



TR 039

24 FR



TR 005

16 FR



TR 062

15 FR



TR 042 A

12 SG



TR 042 B

15 FR



TR 053

80 FR



TR 023

12 FR



TR 080

36 SG



TR 012

15 FR



TR 013

15 FR



TR 061

12 FR



TR 040

15 FR

TR 90

12 FR

TR 085

15 FR

TR 083

15 FR



A

B

TR 041 A 12 SG | B 15 FR

TR 065

4SG

TR 015

27 FR

TR 084

15 FR



TR 014

15 FR

TR 078

15 FR

TR 058

15 FR

TR 076

9 FR



TR 065

TR 090

TR 078

TR 040

TR 041

TR 083



3/97, J.Karia industrial Estate, Musa Killedar Street, Jacob Circle, Mumbai - 400 011. Tel: +91-22-23095378 / 81 Cell: +91 8452002494  
E-mail: info@themonarch.in www.opticaldisplay.net





TR 074



TR 072



TR 044



TR 079



TR 079



TR 082



TR 079

8 FR



TR 059

15 FR



TR 060

12 SG



TR 072

12 SG



TR 078

15 FR



TR 079

12 FR



TR 044 PRESENTATION TRAY



TR 073

12 SG



TR 082

12 SG



TR 051 (B) PRESENTATION TRAY



TR 075

12 FR



TR 074

5 SG

# LENS TRAYS



TR 051 (A) PRESENTATION TRAY



DT 4 LINE DRAWER



LT 001 12 LENS



LT 007 9 LENS



CT 008 (B) 17"x14"



LT 004 12 LENS



LT 003 30 LENS



Lens Cleaner Bottle Tray With Light OI 013



LT 005 6 LENS



DT 3 LINE DRAWER



CT 008 (A) 17"x12"



Lens Cleaner Bottle Tray With Cutwork OI 014



OI 014



TR 051 (A)



OI 013



LT 003



LT 007



CT 008 (A)





# COUNTER TRAYS



**CT 001**      **16" x 26"**



**CT 002**      **14" x 12"**



**CT 003**      **20" x 6"**



**CT 004**      **16" x 6"**



**CT 010**      **DRAWER**

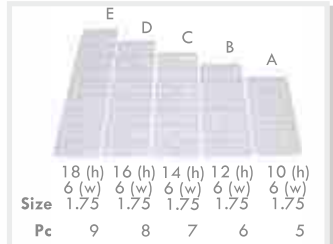

**CT 011**



**CT 013**      **14" x 6"**



**CT 014**      **14" x 6"**



**CT 015**      **18" x 6"**



**CT 018**      **20" x 6"**



**CT 022**      **16" x 6"**



**CT 023**      **14" x 14"**

## MIRRORS

ACRYLIC MIRRORS  
COUNTER MIRRORS  
METAL MIRRORS  
WOODEN MIRRORS  
HANGING MIRRORS



We offer an extensive range of innovative and high quality mirrors. Our materials are varied: acrylic, metal, wood etc. and a high quality. Our finish is what is our U.S.P. Available in different sizes and specifications and in customized forms to meet various needs.





**MI 001**

Matty



**MI 002**

Metal



**MI 004**

Acrylic



**MI 003**

Rosewood  
Natural Wood



**MI 007**

Metal



**MI 006**

Metal



**MI 005**

Metal



**MI 022(A)**

Rubber Wood

**MI 022(B)**

Rosewood



**MI 023**

Acrylic



**MI 010**

Acrylic



**MI 018**

Acrylic



**MI 025**

Sumica



**MI 024**

Metal



**MI 027**

Acrylic



**MI 026**

Acrylic



**MI 028**

Acrylic



**MI 032**

Acrylic



**MI 029**

Acrylic



**MI 036**

Wooden



**MI 035**

Acrylic



**MI 037**

Acrylic



# EYE WEAR DISPLAY FLOOR UNIT



REVOLVING & NON-REVOLVING  
EYE WEAR DISPLAY STANDS

FLOOR STANDING STANDS  
COUNTER TOP STAND

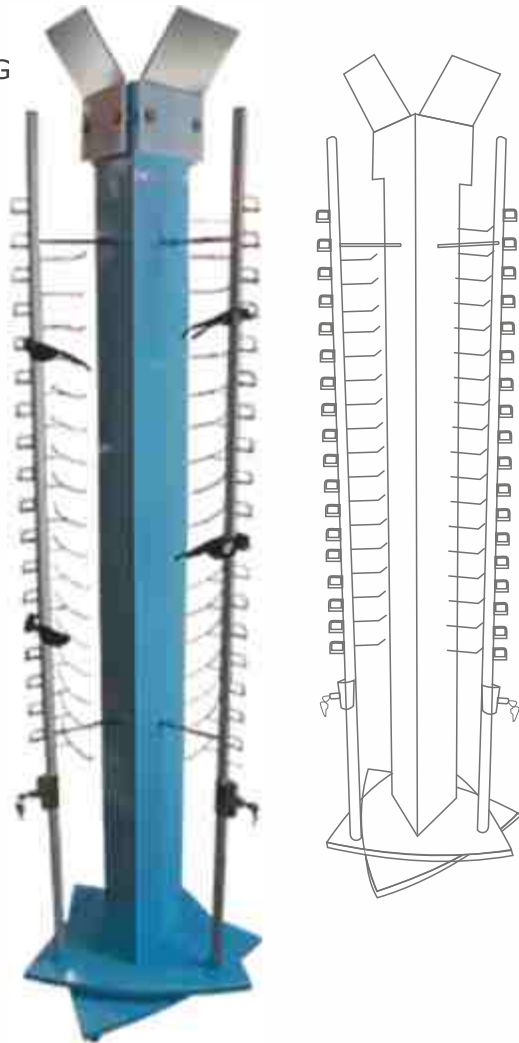

We offer the widest range of innovative and high quality revolving or non-revolving eyewear display stands. our materials are varied: acrylic, metal wood etc. and of a high quality. our finish is what is our U.S.P. available in different sizes and specifications and is customized forms to meet various needs.



**RV 014**



**RV 030 (B)**

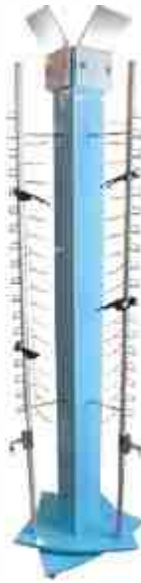

**RV 034**



**RV 043**



**RV 046**



**RV 044**



**RV 045**



**NRV 113**





**RV 108**



**RV 051**



**RV 052**



**RV 148**



**RV 125**



**RV 107**



**RV 126**



**RV 129  
LOCKABLE &  
NON-LOCKABLE  
(WITH LIGHT)**





**RV 130**



**RV 131**

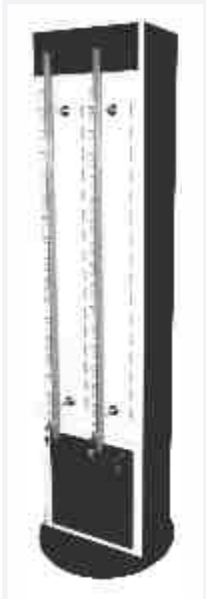

**RV 132**

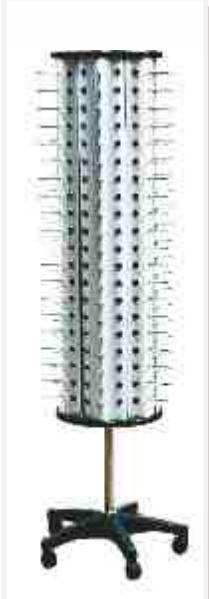

**RV 134**



**NRV 047**



**RV 140**



**RV 142**



**NRV 039**



# TABLE TOP DISPLAY STANDS



**RV 007**



**RV 012**



**RV 048(A)**

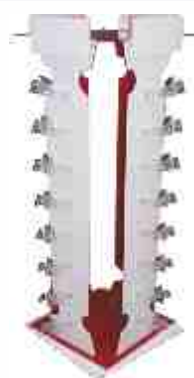

**RV 053**



**RV 117**



**RV 115**



**RV 123**



**RV 120**



**RV 139**



**RV 144**  
With Motor & Light



**RV 141**



**NRV 013**

## POSTER AND BRANDING DESIGN



## ACRYLIC DISPLAYS

MULTI FRAME ACRYLIC DISPLAYS  
FANCY ACRYLIC DISPLAYS



We offer the widest range of innovative and high quality Acrylic Eyewear Displays. We offer single or multi product and fancy acrylic displays. Technically perfect and advanced in design our displays are available in different sizes and specifications and in customized forms to meet various needs.



**AD 001**



**AD 006**



**AD 009**



**AD 013**



**AD 016**



**AD 018**



**AD 019**



**AD 021**



**AD 022**



**AD 023**



**AD 025**



**AD 034**





**AD 035**



**AD 036**



**AD 042**



**AD 056**



**AD 057**



**AD 058**



**AD 061**



**AD 062**



**AD 064**



**OSD 026(A)**



**AD 065**



**AD 066**



**NOS 001**



**NOS 002**



**NOS 003**



**AD 066(B)**



**FC 107**

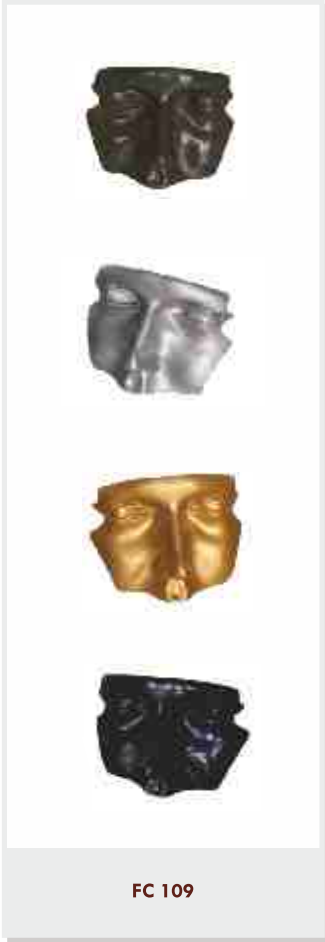

**FC 109**



**AD 067**



**AD 068**







**AD 069**



**AD 071**



**AD 073**



**OSD 007**



**OSD 009**



**OSD 010**



**OSD 011**



**OSD 012**



**AD 074**



**OSD 019**



**OSD 026(B)**



**AD 078 WITH LED**



**LED Chashma**

Outdoor / Indoor Display Sign  
Hanging Display



**OSD 004**

**A1**

**A2**

**A3**

**A4**

**A5**



**AD 072**



## MISCELLANEOUS DISPLAYS

BAG SETS

TROLLEYS

EYEWEAR CASES



We offer the widest range of innovative and high quality Optical Accessories and Miscellaneous components. Technically perfect and advanced in design, our displays are available in different sizes and specifications and in customized forms to meet various needs.



**A TL 001**



**TL 006 (B)**



**TL 007**



**TL 008**



**TL 009**



**HUT 003 (B)**





**CA 002**



**BS 002** 14-15  
School Bag Tray Capacity



**BS 007** 6-8-10-15  
Tray Capacity



**BS 009** 10  
Shell Trolley Bag Tray Capacity



**BS 010** 12 Tray Capacity



**BS 011** 12 Tray Capacity



**CA 004**



**CA 006** Prescription Cover



**CA 009**



**OI 003**



**OI 012**



**HD 001**

# FOLDING PORTABLE STAND FOR EYE CAMPS

64 FRAMES DISPLAY

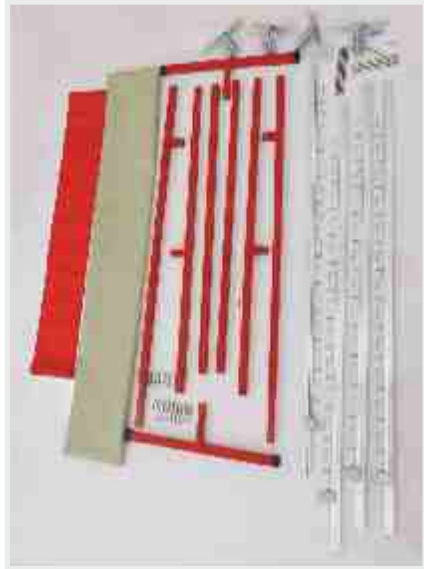

3/97, J.Karia industrial Estate, Musa Killedar Street, Jacob Circle, Mumbai - 400 011. Tel: +91-22-23095378 / 81 Cell: +91 8452002494  
E-mail: info@themonarch.in www.opticaldisplay.net

# MODULAR FURNITURE



				
<b>ME N 001</b>	<b>ME N 002</b>	<b>ME N 003</b>	<b>ME N 004</b>	<b>ME N 005</b>
				
<b>ME B 003</b>	<b>ME B 004</b>	<b>ME B 005</b>	<b>ME B 006</b>	<b>ME NB 001</b>
				
<b>ME FC 001</b>	<b>ME FC 002</b>	<b>ME FC 003</b>		



**ME N 006**



**ME N 007**



**ME N 008**



**ME B 001**

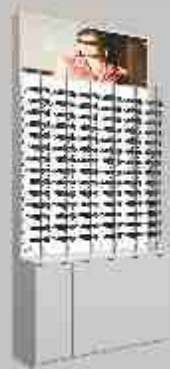

**ME B 002**



**ME NB 002**



**ME NB 003**



**ME CU 001**



**ME ST 001**



**ME CC 001**



**ME CC 002**



**ME EU 001**







**OSD 030**

WOODEN



**OSD 033**

WOODEN



**OSD 034**

WOODEN



**OSD 031**

WOODEN



**RV 160**

WOODEN



**MI 039**

WOODEN



**OSD 032**

WOODEN



**MI 038**

WOODEN



**OSD 035**

WOODEN



**TR 060**

WOODEN



**DT 006**

WOODEN



**LED BIG CHASHMA**



**AD 085**

ACRYLIC



**AD 086**

ACRYLIC



**AD 087**

ACRYLIC



**AD 088**

ACRYLIC



**AD 089**

ACRYLIC



**AD 090**

ACRYLIC



**AD 092**

ACRYLIC



**MI 040**

ACRYLIC



**AD 091**

ACRYLIC



**AD 093**

ACRYLIC



**MI 041**

HANGING



**LED CHASHMA MIRROR**





# TMDMP

## The Monarch Dream Maximization Process.

01

### TMDMP - The Monarch Dream Maximization Process MINING



INITIAL BRIEFING & APPOINTMENT FIXING  
ON SITE MEETING WITH CLIENT

SITE SCANNING

EG:

AREA & GEOGRAPHY  
BUSINESS AREA  
COMPETITOR  
BUSINESS MODULE  
TARGET CUSTOMERS  
NEARBY AND IN HOUSE FACILITIES

SIZE SURVEY

STRUCTURE AUDIT  
SITE PHOTOGRAPHY

CLIENT PROFILING  
CLIENT REQUIREMENT & BRIEFING

MILESTONE PLANNING

02

### TMDMP - The Monarch Dream Maximization Process SCALING



EXISTING LAYOUT REPRESENTATION

ZONE DIVISION AND AREA CREATION  
FOR VARIOUS INVENTORY & SERVICES

EG:

FRAMES  
SUNGLASSES  
HIGH RANGE  
CONTACT LENSES  
EYE TESTING  
FRAME FITTING

DRAWING OUT A DETAILED PLAN

COMMUNICATING THE PLAN TO THE CLIENT VIA E-MAIL

COMMUNICATING WITH CLIENT & EXPLAINING PLAN  
& LAYOUT INCORPORATING REVISIONS

FINALISATION OF PLAN & LAYOUT



03

### TMDMP - The Monarch Dream Maximization Process VISUALIZATION



DETAILED DESIGN LAYOUTS  
EG:  
FALSE CEILING  
ELECTRICAL LAYOUT WITH LEGEND

PRECISE SELECTIONS  
EG:  
COLOUR COMBINATION  
MATERIAL SELECTION

IMAGING  
EG:  
3 CAMERA VIEWS PER SHOWROOM  
BIRDS EYE VIEW OF SHOWROOM  
ALL THE 3D IMAGES TO CLIENTS VIE E-MAIL

REVISION INCORPORATION

FINALISATION OF 3D IN ALL THE ABOVE ASPECTS

04

### TMDMP - The Monarch Dream Maximization Process Valuation



FINALISATION  
EG:  
MATERIAL  
COLOUR  
ACCESSORIES  
LIGHTS  
EXTRAS

PRECISE SIZE CALCULATIONS FOR UNITS

QUANTITY CALCULATIONS OF FURNITURE

PROVIDING PRECISE COSTING

ADDING OF TAXATION

FINALISING QUOTATION WITH CLIENT

05

### TMDMP - The Monarch Dream Maximization Process REEL TO REAL



DETAILED LAYOUTING FOR ALL THE FURNITURE  
COMMUNICATION OF DETAILED DRAWINGS TO FACTORY  
MATERIAL PROCUREMENT  
STARTING OF PRODUCTION  
QUALITY CHECK  
MOCK REPRESENTATION OF THE SHOWROOM  
TRANSPORTATION OF FURNITURE  
INSTALLATION ON SITE  
SITE FINALISATION  
NEW SITE PHOTOGRAPHY  
SITE HAND OVER

# MODULES



Technical Perfection  
 Aesthetically Designed  
 Designed by Experts in Optical Outlets  
 Customized Size & Finish

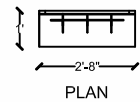
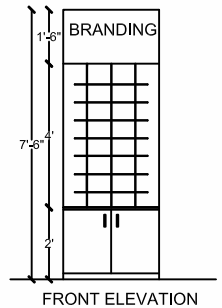

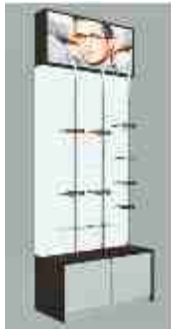

ME NB 004



ME N 003



ME EU 001



ME ST 001





# IDEAL MODULAR SHOWROOM

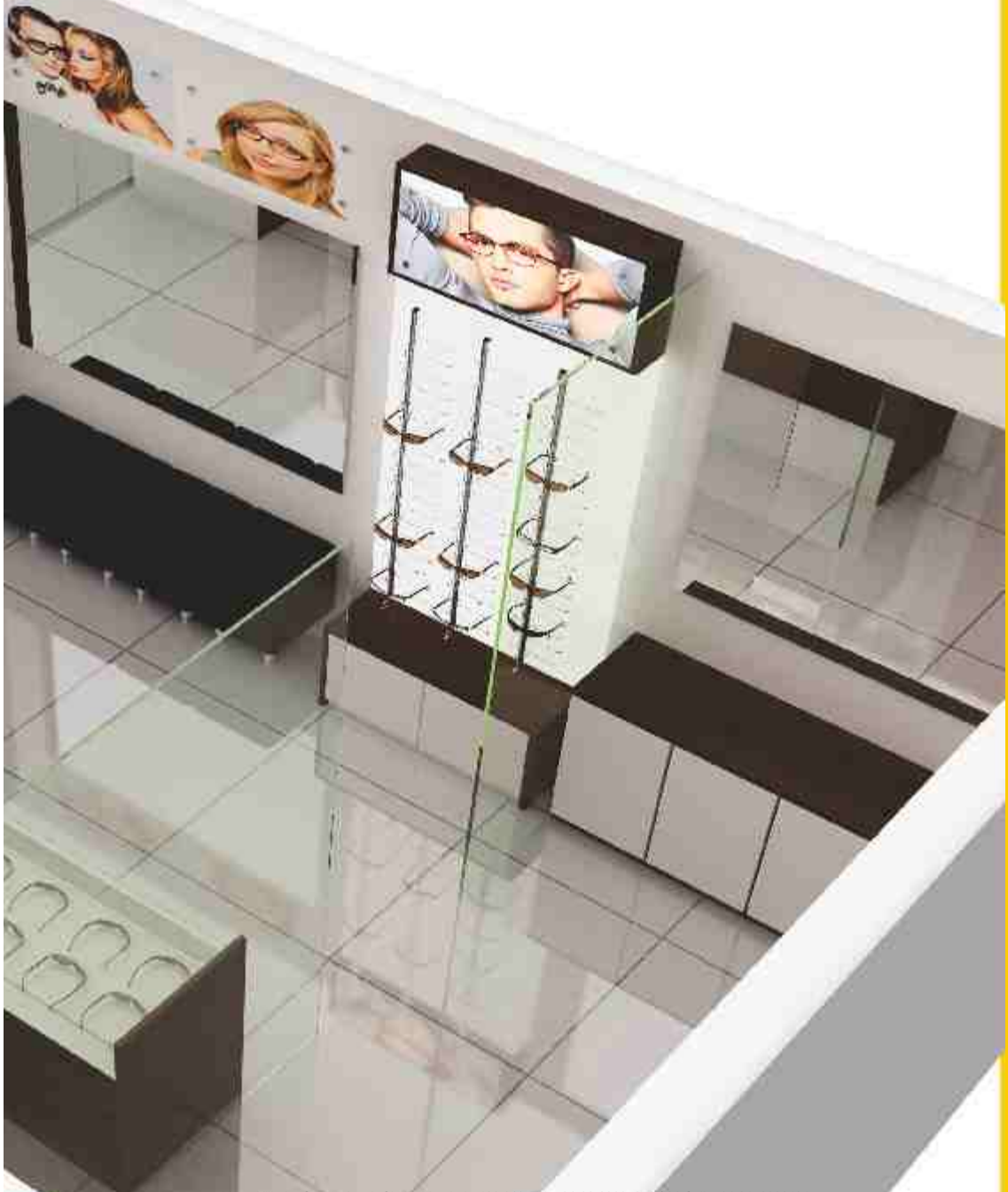



## **M THE MONARCH ENTERPRISES®**

3/97, J. Karia Industrial Estate, 35/43, Musa Killedar Street,  
Near Byculla Station (W), Jacob Circle, Mumbai - 400 011.

Email : [creativemonarch@gmail.com](mailto:creativemonarch@gmail.com) Tel.: 022 2309 5378 / 2309 5381

[www.opticaldisplay.net](http://www.opticaldisplay.net) / <http://opticaldisplay.net/downloads/catalogs/>

FaceBook : <https://www.facebook.com/www.eyeweardisplay.in/>

Twitter : <https://twitter.com/murtazafin1>

Linked In : <https://in.linkedin.com/in/murtaza-finwala-a1512b39>

Instagram : [https://www.instagram.com/the\\_monarch\\_enterprises](https://www.instagram.com/the_monarch_enterprises)

Pinterest : [www.pinterest.com/the\\_monarch\\_ent](http://www.pinterest.com/the_monarch_ent)